

2016 CYNCR A OWNER'S MANUAL

Last Revision: 11-2018



5610 4th Ave. S. Seattle, WA 98108 **U. S. A.**
(t)+1. 206.764.0600 (f) +1. 206.764.0601
www.synesso.com

TABLE OF CONTENTS

Introduction	3
Safety Warnings	4
Warranty & Water Standards	5
Installation	6-7
Installation Prep Guides	8-9
Plumbing Requirements	10
Electrical Requirements	11
Operation	12-14
Machine Options	14-15
Programming Machine Functions	16-21
• Brew Temperature Control	17
• Auto Flush	18
• Steam Temperature Control	19
• Hot Water Tap / Serial Number	20
• Error Codes	22
Maintenance	22-23
Troubleshooting	24-26
Annual Warranty Checklist	27

INTRODUCTION

These are Original Instructions. Congratulations on the purchase of your Synesso™ Cyncra 2016 espresso machine. Please read this Owner's Manual and retain it in a safe location for future reference. If you have any questions about your machine, please contact Synesso™ and our knowledgeable staff will assist you.

Factory Contact Information:

Synesso™ Inc.
5610 4th Ave South
Seattle, WA 98108 - USA
Tel: +1.206.764.0600 / Fax: +1.206.764.0601

E-mail: info@synesso.com
Web: www.synesso.com
Twitter: @SynessoFactory
Instagram: Synesso_factory
Facebook: Synesso

Please have your Serial Number available **BEFORE** calling for service or technical support. Thank you.

S/N: _____

The **OFFSETS** for this machine are:

BG1: _____ °F / BG2: _____ °F / BG3: _____ °F

Steam Tank: _____ °F

Factory Temperature Settings:

Brew Tanks: 203 F (95 C) Steam Tank: 250 F (129 C)

Included in the package with this machine you will find the following:

- Thumb Drive containing the Owner's Manual and other technical documents
- Pump/Motor Combination + hoses (3/8" compression fittings on all hoses)
- 8' Flexible 3/4" ID drain hose + hose clamp (attached)
- Fitting, 1/4" male NPT x 90° x 3/8" Compression (if not CE/C-Tick)
- Accessory Package: Portafilters (per customer specification), blind basket, Synesso™ 3 oz. (90ml) shot glass, JoeGlo™ cleaning kit, 58mm tamper, 4 rubber leg pads
- Electrical plugs are ONLY included on CSA Certified machines (Canada). For all other machines, the owner of the machine must purchase an appropriate plug end for their machine.

Serial Number

Your espresso machine has a unique serial number, located on the left inner frame of the machine, just under the drain tray on a serial plate. The number can also be read on the display during start-up or on the "Synesso" screen (see page 18). Please have this serial number available for reference when contacting the factory.

Understanding the information displayed in the serial number. i.e.: 307152350

3 - is the number of groups on this machine (this is a 3 group machine)

07 - is the month it was built (July is 07)

15 - is the year it was built (15 is the year 2015)

2350 - is the machine sequence number for all machines built by Synesso

SAFETY WARNINGS

IMPORTANT Information for Synesso™ Espresso Machines: **DISCONNECT FROM POWER BEFORE SERVICING.**

- Read the entire manual before operating this machine.
- Steam and condensation from the steam wand discharge are very hot and may cause burns.
- The steam wand tips and bases become hot during use: do not touch these surfaces.
- Cover the steam wand tip or submerge in a filled pitcher to safely divert the steam before opening the steam valve.
- Never remove the steam wand from the product that is being heated when the valve is open.
- Never remove the portafilter from the machine during the active brewing process.
- Keep water and moisture away from any electrical device or live power.
- Steam tank water is heated to 260°F (126°C) or more; Use caution near steam tank.
- The brew groups deliver water as hot as 210°F (99°C). Avoid exposure to this water.
- The hot water mix valve can be adjusted to deliver water as hot as 212°F (100°C), which can cause severe burns: please use caution when activating this water source.

Safety Label Locations:

Synesso™ complies with UL regulations by posting the following labels on its machines:

Electrical Box:	<p>WARNING: Disconnect from power supply before servicing</p> <p>AVERTISSEMENT: Couper l'alimentation avant l'entretien et le dépannage.</p>	California only:	<p>CALIFORNIA PROPOSITION 65 WARNING</p> <p>WARNING: This product contains chemicals known to the State of California to cause cancer and birth defects or other reproductive harm. (California law require this warning to be given to customers in the State of California)</p>
Electrical	<p>The conductors of the power supply cord are marked "L1", "L2" for the ungrounded ("hot") supply conductors and "G" for an equipment grounding lead.</p>		<p>Warning: Risk of Fire. Use UL Listed Grounding Type Plug rate for 220 Volts, _____ Amperes, _____ Phase, # _____ Wire. Plug to be Selected and Installed only by Qualified Service Personnel.</p>
Under drain tray	<p>This equipment is to be installed to comply with the applicable federal, state or local plumbing codes.</p>		

Materials information for Synesso™ machines:

- All stainless steel coming into contact with the water supply is 300 series
- All brass fittings are low lead per the CA360 specifications or better
- All electronic devices are lead free
- All gaskets are made from food-contact safe material

Test Information

- Brew (coffee) tanks are hydrostatically tested to 375 psi
- Steam tanks are pressure tested to 75 psi
- The electrical system is subject to an electrical withstand test of:
1.20 kvac, at 5.00 mA, for 1 second

WARRANTY & WATER STANDARDS

Limited 2 Year Plus Warranty

Synesso Inc. and/or your Distributor warrants to the original purchaser that Synesso espresso machines are free from defects in materials and workmanship under normal use and service for the period commencing upon the date of shipping and continuing for 24 months from the original date of shipment. Synesso will make a good faith effort for prompt correction or other adjustment with respect to any non-wearing part that proves to be defective within the limited warranty period. This Limited Warranty is conditional upon proper use of the machine by the purchaser.

This Limited Warranty does not cover defects or damage resulting from: accident, misuse, abuse, shipping damage, neglect, unusual physical, electrical or electromechanical stress, unauthorized customer modifications or improper water filtration.

The 2 Year Plus Warranty* will cover all non-wearing parts including:

- Universal Brew Tank
- Steam Tank
- Marathon Motor
- Fluid-o-Tech Pump
- Pressure Relief Valve
- 1/4" Check Valves
- Thermal Overload Switch with Manual Reset
- Brew and Water Control Valves

In addition to the standard 2 Year Plus Warranty*, Synesso will cover the following items under a Limited 5 year Warranty:

- Group Head Assemblies
- Steam Valve Actuator
- Machine Body
- Machine Frame
- Sight Glass
- Heating Elements
- Wire Harness
- Copper Tubes
- Brass Fittings
- Temperature Probes

Wearing parts not included in the 2 Year Plus Warranty* are:

- Portafilter Gaskets
- Portafilter Baskets
- Portafilter Springs
- Group Diffuser Screens
- Vacuum Breaker
- Steam Valve Seals
- O-Rings or Seals
- Gauges
- Body Panels - One Year Warranty

***To obtain the 2 Year &/or 5 Year Plus Warranty, the annual Preventative Maintenance Guide and checklist must be completed by a qualified Synesso Technician. After twelve months from the original date of shipment, the completed checklist must be emailed to the Synesso Technical Support Department. [Tech@Synesso.com] Checklists must be received before the thirteenth month from the original date of shipment in order to be valid. See page 27 for the Annual Preventative Maintenance Checklist.**

WARRANTY & WATER STANDARDS

Proper water filtration and regular filter changes are a requirement to keep your factory warranty valid and your machine functioning properly. It is highly recommended that you contact a professional water filtration specialist in your area and have your water tested to determine the proper filtration system. It is important to note that many municipalities change their water sources throughout the year, so additional water tests may become necessary.

Water Standards to keep your warranty valid:

Total Dissolved Solids (TDS)	30 to 200 ppm (parts per million)
Total Hardness - in ppm	Less than 85 ppm
Total Hardness – in grains	3 to 5 grains (divide ppm by 17.1 to get grains)
pH	6.5 pH to 7.5 pH
Chloride	5-15 ppm – any Chlorides can be corrosive and harmful
Total Alkalinity	Less than 100 ppm
Chlorine	0 ppm
Iron	0 ppm

In Synesso’s experience, Everpure Claris and Cirqua formulator systems can damage the Synesso stainless steel tanks. Use of either system is highly discouraged and will void the water related parts of the machine warranty.

Any part which is determined to be defective in materials or workmanship should be returned to Synesso or to an authorized service location, shipping costs prepaid, as Synesso designates. Synesso may repair or replace the product or part with new or factory refurbished equipment at Synesso’s sole discretion. If the product or part is determined to be defective and in compliance with the Limited Warranty conditions, the replacement part or product will be returned to the purchaser with shipping prepaid **.

Many jurisdictions have codes and regulations governing sales, construction, installation, and/or use of products for certain purposes, which may vary from area to area. While Synesso attempts to assure that its products comply with such codes, it cannot guarantee compliance and cannot be responsible for how the product is used or installed.

Synesso’s liability is limited to the purchase price of the product and shall not be held liable for damages that extend beyond the product itself. Synesso’s liability of consequential, incidental damages, indirect or direct damages for personal injury, inability to properly use this product, loss of business profits or interruption to business is expressly disclaimed.

** Regarding equipment sold or residing outside the United States: purchaser maybe required to pay for the shipping and associated costs for warranty parts, repairs and services. Please contact your local distributor to resolve the issue regionally, if possible.

INSTALLATION & WORK STATION

To maintain the 2 year warranty, an authorized or certified espresso service representative must perform the installation of this espresso machine.

Site Preparation - See Diagram on page 7. The machine must be placed on a level horizontal surface that can be easily cleaned and is capable of sustaining a minimum of 300 lbs.

The counter top requires a depth of 28", which provides a minimum clearance of 1" behind and 3" in front of the machine.

The height of the surface can vary to suit the operator.

Make a 2 ½" minimum diameter hole through the counter top located 4" from the rear and 7" from the right side of the machine. The hoses, drain tube, and electrical lines will all pass through this hole.

A 3/8" min. diameter cold water supply line from the filter with a shut off valve is required within 5' of the machine. The valve should be easily accessed for machine service.

The machine supply hose and pump fittings are 3/8" tube compression fittings.

A proper water filtration or softening system must be installed on the incoming water supply. Water treatment requirements will vary, and it is important to use a system designed to match the needs of your specific area. Water filtration systems require periodic maintenance, including cartridge or filter replacement. Proper filtration and service is vital to the function of the machine and the quality of the espresso served. Follow the instructions provided by your water treatment system for proper installation.

Note: Improper water filtration can result in severe damage to the machine including scale deposits and corrosion. **DAMAGE CAUSED BY IMPROPER WATER TREATMENT WILL NOT BE COVERED BY THE MACHINE WARRANTY.** See page 6

There must be adequate room under the counter to locate each motor and pump. The pumps must be easily accessible for adjustment and motors must have a minimum of 3" clearance on all sides for air flow.

A floor drain or sink must be available. The best location is directly under the machine. The 3/4" drain hose should descend as vertically as possible for optimal drainage. An air gap is required between the end of the drain hose and the highest water position of a clogged drain. This is to prevent the possibility of drain water backing up into the machine.

INSTALLATION & WORK STATION

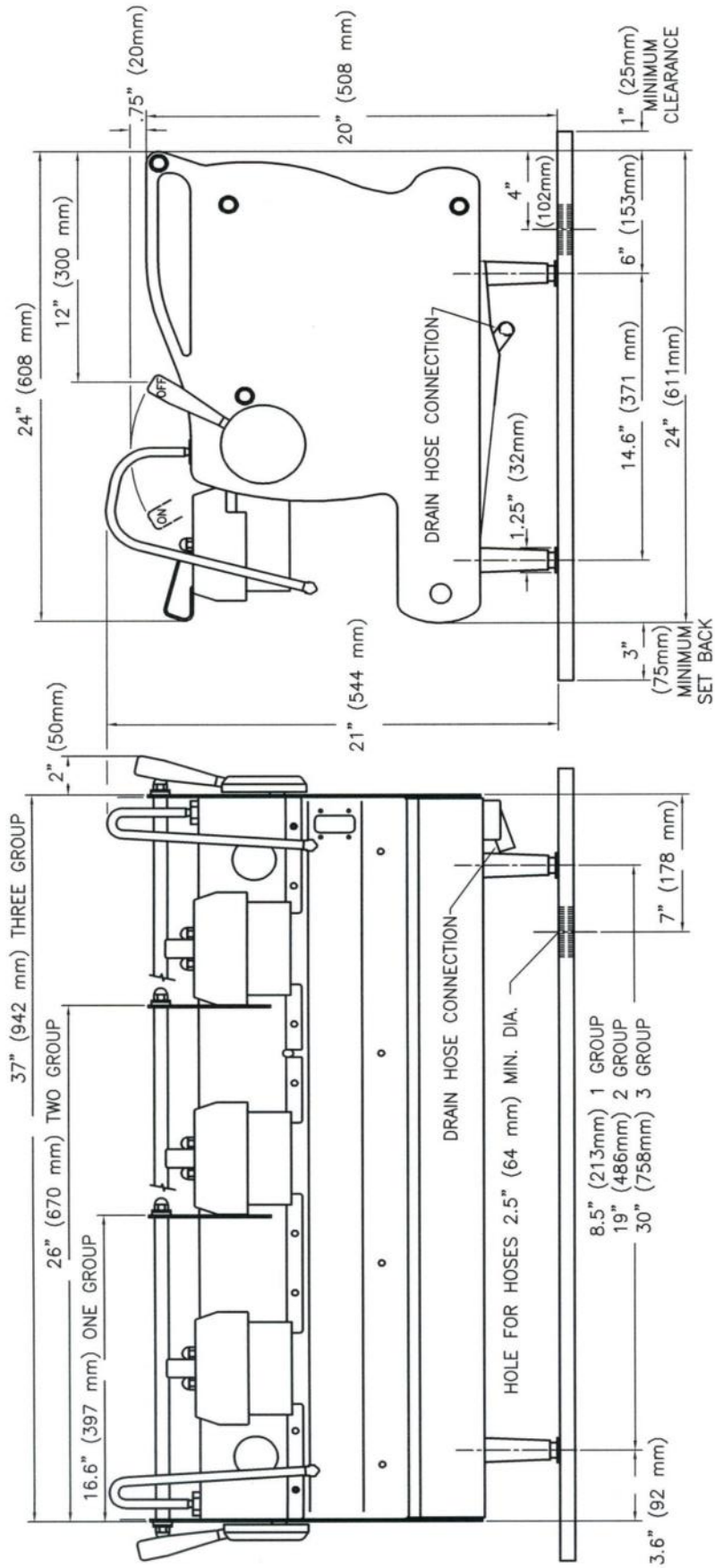

RIGHT HAND END VIEW

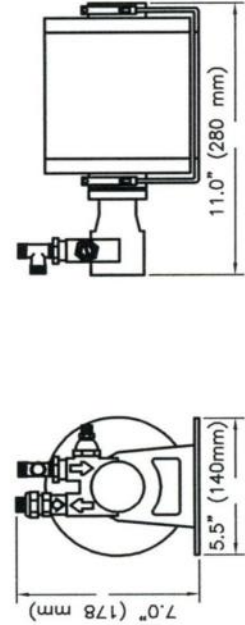

PUMP AND MOTOR

2 GROUP CYNCR A INSTALL PREP GUIDE

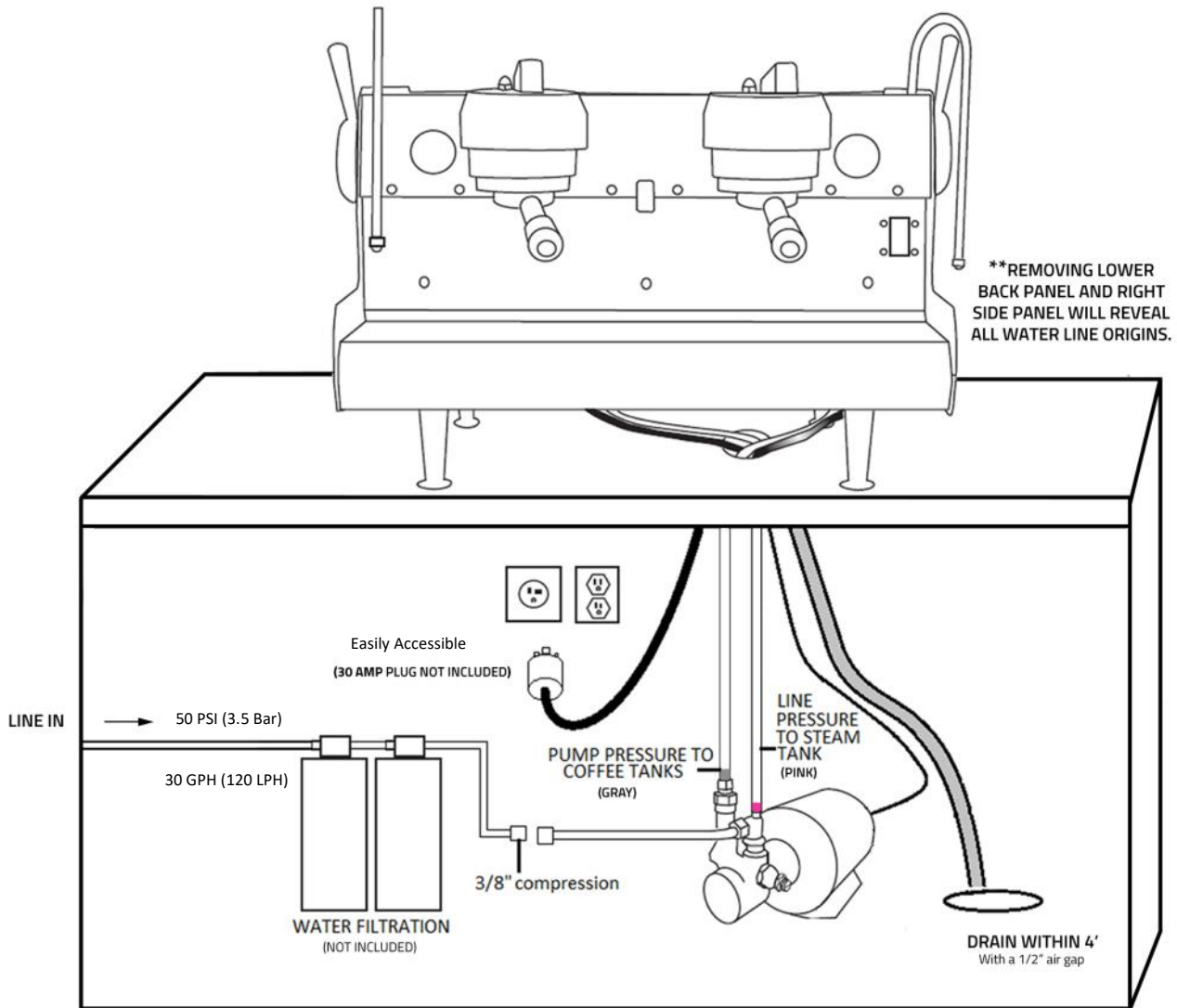

QUICK REFERENCE SPECIFICATIONS

DIMENSIONS: 21"(H) 30" (W) 24"(D)

WEIGHT: 173 lbs (full)

ELECTRICAL: Volts: 220 / Amps:28 (230 V / 5956 Watts)

PLUMBING: Line pressure of 50psi (minimum) (3.5 Bar)

FITTING: 3/8" compression w/ shut off

DRAINAGE: Within 4 feet of machine

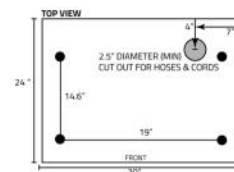
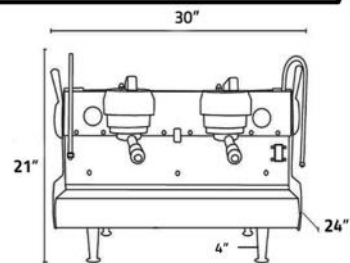

3 GROUP CYNCR A INSTALL PREP GUIDE

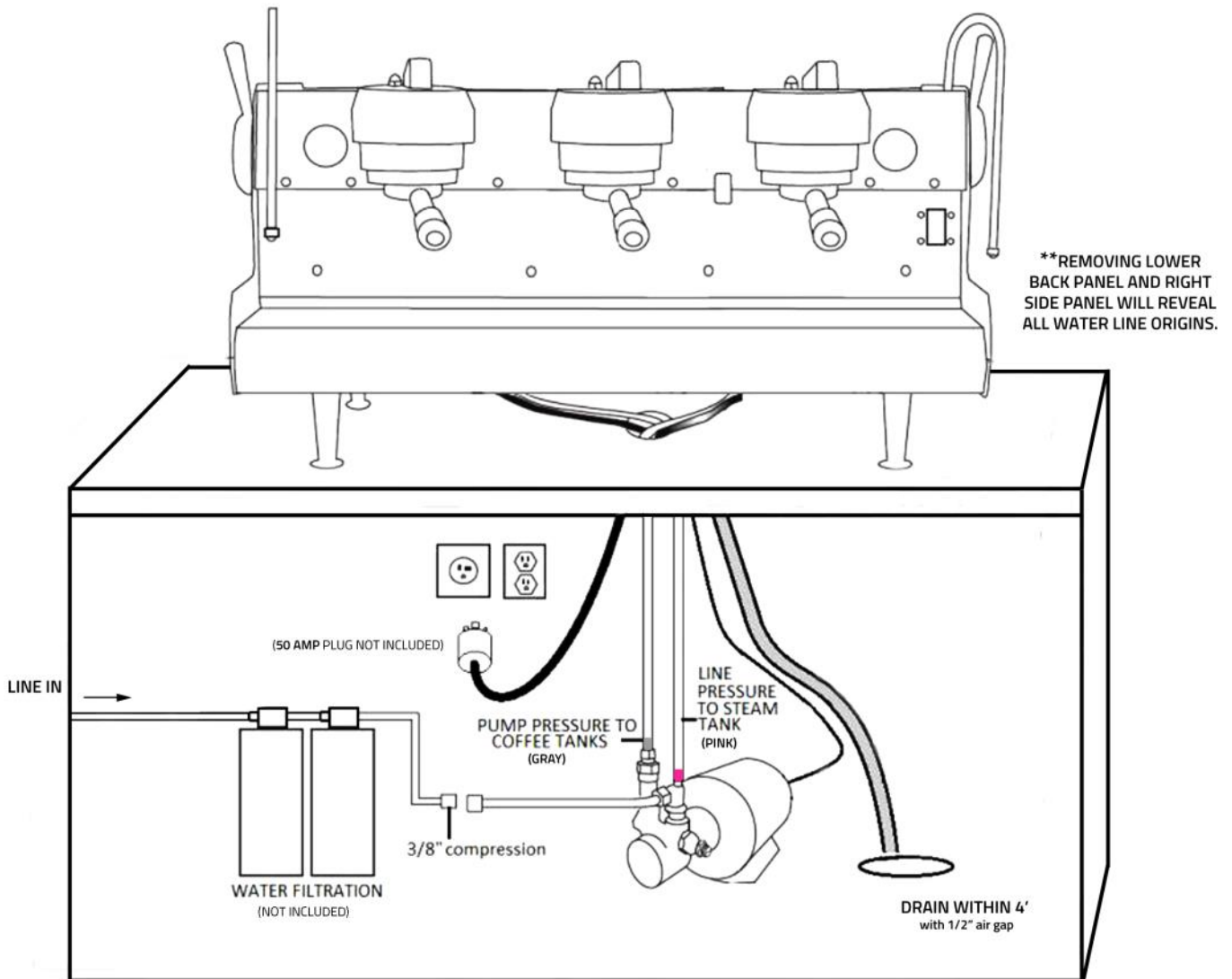

QUICK REFERENCE SPECIFICATIONS

- DIMENSIONS:** 21"(H) 41" (W) 24"(D)
- WEIGHT:** 218 lbs (full)
- ELECTRICAL:** Volts: 220 / Amps:36
- PLUMBING:** Line pressure of 50psi (minimum)
- FITTING:** 3/8" compression w/ shut off
- DRAINAGE:** Within 4 feet of machine

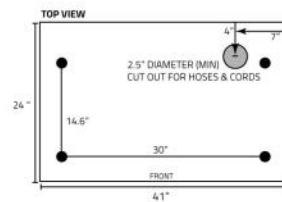
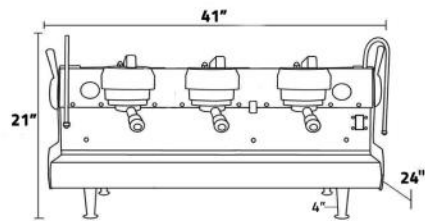

PLUMBING REQUIREMENTS

This equipment must be installed to comply with the applicable federal, state or local plumbing codes. WATER TREATMENT IS REQUIRED TO PRESERVE THE FULL MACHINE WARRANTY. Please ensure that the incoming water complies with the warranty requirements listed on page 5.

Using the provided stainless steel braided hose, connect the pump to the shutoff valve on the filtered cold water line. Fittings on the hoses and pumps are 3/8" tube compression. Thread sealant or Teflon tape is not necessary. Make connections snug, but do not over tighten.

Turn incoming water ON and check for leaks.

Synesso™ machines require a minimum of 50 PSI (3.5 bar) of line pressure at 30gal (120L) per hour to have the auto-fill system for the steam tank function properly. Please ensure that the incoming water meets this requirement or contact Synesso™ for alternative methods of boosting water pressure.

NOTE: Synesso™ sells a "Euro-hose" adaptor hose and fitting (part number is 1.5020) which converts from a 3/8" tube fitting to a pipe fitting, suitable for most non-US plumbing. Please refer to the picture below to identify the differences between the standard and Euro-style fittings and hoses.

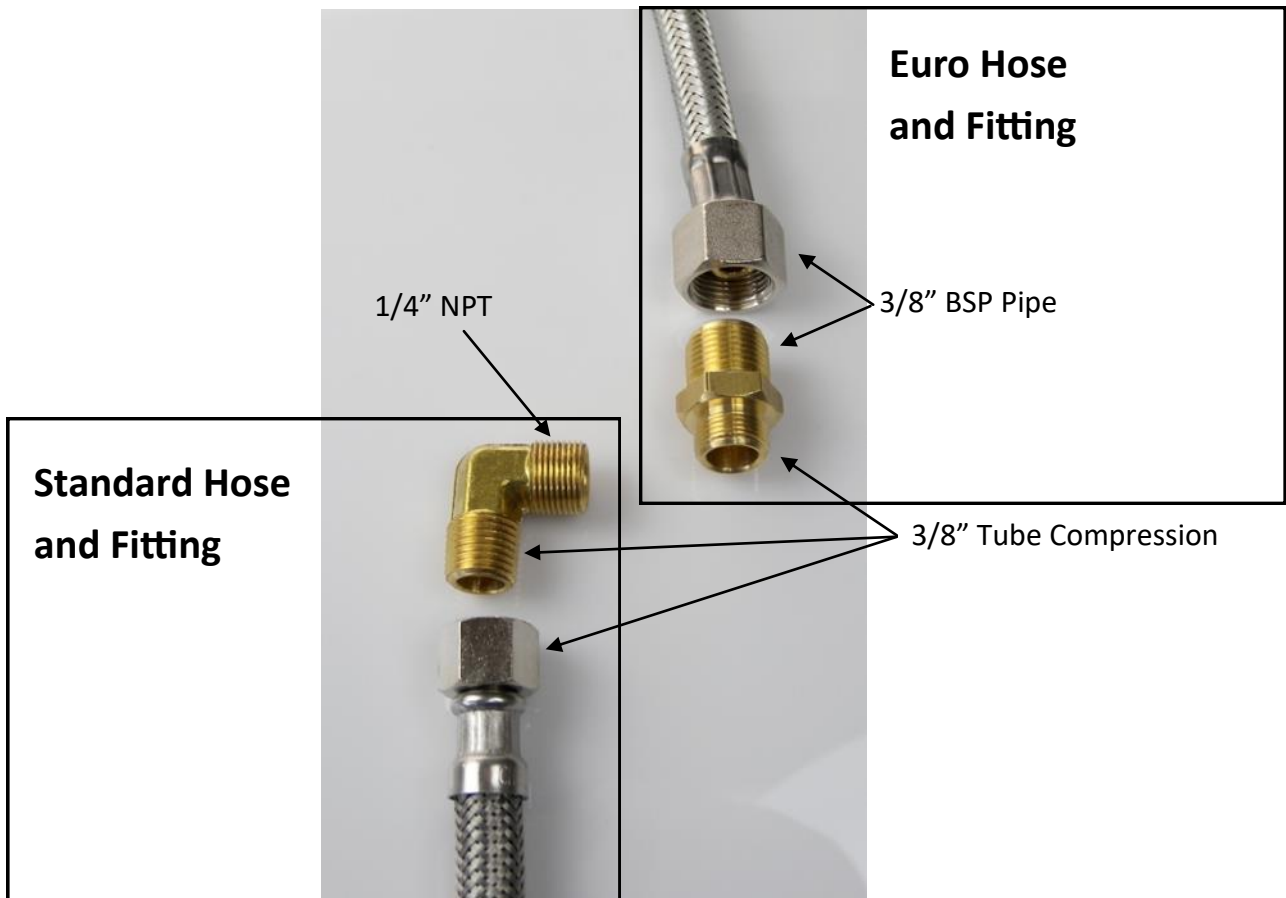

ELECTRICAL REQUIREMENTS

All Synesso™ machines are rated to operate on 220v / 60 Hz or 230v / 50 Hz frequency, single phase. Machines will operate between 208v and 240v.

Listed amp ratings are all measured at 220v. Incorrect voltage can cause malfunction or damage to the machine. **Plug or means of isolation must be easily accessible.**

An electrical socket and matching plug, rated at the proper voltage and amperage are required within three feet of the machine. Plug ends are NOT included with the machine unless required by CSA or other certification.

Model	Cord Plug Rating (UL Listed)	Machine Max Amp Draw	Machine Max Watts
2 Group Cyncra	30 amp	28 amp, 220v / 60 Hz	5956 Watts, 230v / 50 Hz
3 Group Cyncra	50 amp	36 amp, 220v / 60 Hz	7742 Watts, 230v / 50 Hz

North American Wire Color		Worldwide Wire Color	
Green	Ground	Green and Yellow	Ground (Earth)
White	110v Line 1	Brown	230v
Black	110v Line 2	Blue	Neutral

Attach the plug end per manufacturer's instructions.

Make sure that the red electronics switch and the heating element breaker on the front of the electrical box are in the OFF position, then plug the power cord into the receptacle.

Retighten side panel fasteners after service to ensure proper earth grounding.

OPTIONAL: If recovery time is slow, install an In-Line Buck-Boost transformer to increase voltage below 208v to optimize machine recovery time. Buck-boost transformers come in different sizes. Please choose the appropriate one for your machine if required. 1 and 2 Group Machines require a 1.0 KVA transformer, 3 Group Machines require a 1.5 KVA transformer.

SPECIAL ELECTRICAL INFORMATION FOR EMC-COMPLIANT MACHINES

(C-TICK FOR AUSTRALIA, CE FOR EUROPE AND OTHER LOCATIONS)

To comply with EMC (Electromagnetic Compatibility) regulations, Synesso™ is required to install a capacitor in the electronics box across the main power IN. **To avoid an electric shock from the charge held in the capacitor, unplug or isolate the machine with the electronics ON/OFF red rocker switch in the ON position.**

OPERATION

Start-Up Instructions

1. To fill the machine, connect the water lines, set the drain hose and turn the water ON.
2. Switch the red electronics On/Off switch to ON. This activates the machine's water auto-fill feature for the steam tank and the electronics, but NOT the heating elements.
3. The water level sight glass for the steam tank is located on the right side of the machine. As the tank fills, the water level will rise in the sight glass and will automatically stop when the preset level is reached.
4. Bleed the group heads of air. Turn each group head handle left into the BREW position, (see pictures below) allow the group to run until there is a steady flow of water. Return the group head to the OFF position.
5. Wait until the steam tank has stopped filling and the level in the sight glass reads at least $\frac{1}{2}$ full. Turn the heating element breaker to the ON or (1) position. All the heating elements (brew and steam) are now activated.
6. To adjust the pump pressure, activate the pump by turning the brew group to the BREW position.
7. Locate and read the pump pressure / brew gauge located to the right of the rightmost group
8. Set the pump pressure to 9 Bar:
 - Locate the pump adjusting screw on the right side of the brass pump housing.
 - Loosen the lock nut and turn the screw with a screwdriver:
 - ⇒ Clockwise to INCREASE pressure
 - ⇒ Counterclockwise to DECREASE pressure
 - Once the desired pressure is reached, retighten the lock nut.
9. Please allow at least 30 minutes of "warm up" time before using your Synesso™ espresso machine to brew shots or steam milk. The steam gauge (the left hand gauge) should read a minimum of 1.1 Bar.



Off



Pre-infusion



Brew

OPERATION

LED Digital Shot Timers - NOW INCLUDED

Synesso offers LED shot timers will display how long water has flowed through the group head. The timer is located above its associated group head and the timer starts when the brew valve is opened. The total run time of the last shot is displayed until the next shot is started, at which point the timer resets to 0 and starts counting again.



Prepare a Portafilter

1. For best results, use fresh coffee. Ground coffee should be brewed as soon as possible after grinding.
2. Select the correct spout and basket configuration. Single, double and bottomless portafilters are available through Synesso™. The single spout portafilter is used with a single (7g) basket to brew a single shot. The double spouted or bottomless portafilters can be used with double (14g) or triple (18g or 21g) baskets to brew triple, double, or 2 single shots of espresso.
3. Fill the portafilter basket just above level and wipe off the excess.
4. Press straight down evenly on top of the grounds with the tamper.

NOTE: When not in use, keep the portafilter engaged in the group head to keep it warm.

Espresso Brewing

1. Grind a dose of coffee appropriate to the basket you will be using.
2. Dispense into the portafilter basket.
3. Level the mound and compress using a tamper. (A tamper is supplied with the machine.)
4. Engage the portafilter into the brew group that has the correct temperature setting for this espresso roast and pull firmly to the right to set the seal.
5. Pre-infuse the coffee puck by turning the brew group clockwise to the center position. This allows line pressure to saturate the puck.

NOTE: If a stage 1 (pre-infusion) is set on the display, that will begin automatically when the actuator is switched to the brew position, so the pre-infusion position should be skipped.

6. When a drip shows at the spout (or on the basket if bottomless), Turn the group cap clockwise again to the brew position. This engages the pump.
7. When the stream of coffee turns from brown to “blonde”, end the shot by returning the group cap to the far right position.

OPERATION

Milk Steaming

1. Fill the pitcher halfway with fresh, cold milk. Smaller pitchers are recommended for drink sizes less than 10 oz. steamed, unused milk should be discarded.
2. Condensation can collect inside the wand. Activate the steam handle to blow the wand clear before steaming milk.
3. Insert the tip of the steam wand deep into the milk pitcher. This will prevent milk from splashing once the steam is turned on and open the steam valve by pulling the handle towards you.
4. Place one hand on the side of the steam pitcher to feel the rising temperature of the milk.
5. As the milk agitates and heats, lower the pitcher to keep the tip of the steam wand closer to the surface. Allow the steam jets to push some air beneath the surface, then raise the pitcher to lower the tip of the and deeper into the milk. This will continue the heating process and minimize further foaming. Do not touch the steam wand to the bottom of the milk pitcher; this can create an inaccurate temperature measurement.
6. Heat milk to approximately 150F to 170F (65°C to 76°C). If you are using your hand to help determine the temperature, it will feel about as hot as you can stand without burning yourself. Milk thermometers are also an excellent way to determine the temperature of the milk. **Caution: Do not overheat the milk and scald it. Scalded milk should not be used.**
7. Remove the wand from the milk, purge, and wipe clean immediately after each use.

NOTE: Although Synesso™ steam wands are made with a proprietary double-walled process that helps to keep the outer wall cooler, THE TIP AND BASE CAN BECOME VERY HOT AND CAUTION MUST BE USED.

OPTIONS

Pressure Regulator - Part #1.7635, 1.7636 or 1.7637, This regulator is a device installed on the incoming water line before the pump. It reduces high incoming water pressure to a desirable level (around 50psi). This device is useful in high fluctuation areas where there is variable water use throughout the day (i.e. hotels, apartments). This is easily adjusted by watching the brew gauge while in the pre-infuse position, then turning the handle on the valve clockwise to increase pressure and counter-clockwise to decrease pressure.

Cash Valve - Part #1.7291, A cash valve is an option for single pump/motor, multi-group machines. It is installed on the pump head and functions as a larger pressure adjustment tool, similar in function to the standard hex nut adjuster on the pump head. It can accommodate and control greater variance in water fluctuation than the standard pump adjuster, and is a good tool for situations in which large water fluctuations are seen. Adjust the pump pressure above 10 bar using the adjustable hex nut; then adjust the cash valve to your desired pressure (approximately 9 bar).

Line Pressure Boost System with Pressure Regulator- Part #1.7875_X, This option includes an additional pump, motor & pressure regulator to create line pressure for installations where the water is being drawn from a static tank or the water pressure is too low to have the machine function properly. It is recommended that at least 35 pounds (PSI), preferably 50 pounds (PSI) for proper steam tank filling and to use the pre-infusion abilities. Install diagram is on page 13.

LINE PRESSURE BOOST INSTALLATION DIAGRAM

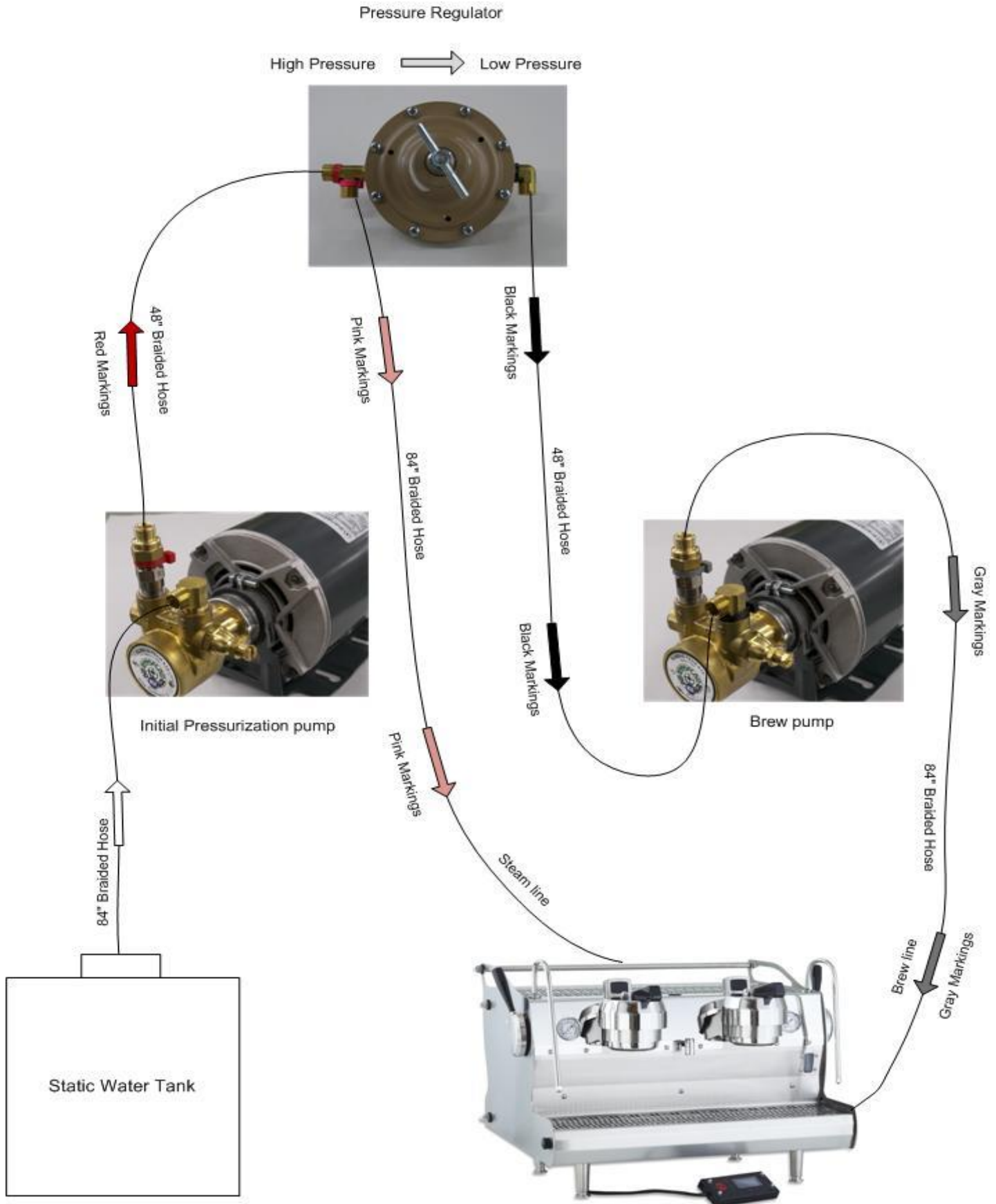

PROGRAMMING

These machines have an updated hand held (wired) keypad, pictured below, to allow the user to comfortably view and change the machine settings.



The 1st line of text indicates the screen title, in this case Temperature Overview.

The 2nd line indicates brew groups 1 and 2 and the associated temperatures (shown in Fahrenheit, can be changed to Celsius)

The 3rd line indicates the temperature of brew group 3, if applicable.

The 4th line indicates the steam tank temperature to the left and Error Codes (if any) to the right

On Line 2 of this Temperature Overview display screen, brew group 1, represented as BG1, if it reads 'LOW' instead of the temperature, this indicates that BG1 is below the temperature probe's range of measurement (170F-270F / 76.6C-132.2C). Readings above the indicated range will show as 'HIGH'.

The lowest programmable temperature for a brew group is 180F (82.2C) and the highest programmable temperature for a brew group is 220F (104.4C). The factory set temperature is 203F (95C). To change brew group set temperatures, refer to page 18.

The steam tank is set by the factory to a default setting of 250F (121.1C). To change this temperature, see page 18.

The [OK] on the right hand side of line 4 is indicating that there are no errors being detected by the control system. If, in place of the [OK] you find an error code (EX: STLW01), refer to the Error Log codes on page 22.

To cycle to the next display screen in the menu level, the 'BG1 Temperature Control' screen in this case, press the Next Screen button.

PROGRAMMING



Line 1 of the BG1 Temperature Control screen indicates the current temperature being recorded by the first position brew group's temperature probe, 202.9F in this example. Once this temperature reaches the set point, it will continuously cycle up and down by small increments as the electronics balance the temperature.

Line 2 is indicating the set point of 203.0F (95.0).

Line 3 indicates the length of time that the stage 1 timer (timed pre-infusion) will run, 3 seconds.

Line 4 is not used on the Cyncra 2016

To change the temperature set point, press the button for line 2. The current temperature setting (202.9F) will begin to flash. To alter the temperature, press the Up or Down Arrow buttons until the desired temperature is reached. Press the button to the left of line 2 to confirm the temperature point. The number will stop flashing.

Line 3 indicates the amount of Stage 1 or "Line Pressure Pre-infuse" time that will elapse before the pump is initiated. (Line pressure can be altered with either a pressure regulator or a boost pump.)

To change the Stage 1 time, press the button associated with line 3. The current time will begin to flash. To alter the time on the indicator, press the Up or Down Arrow buttons until the desired time is reached. Once the desired time is set, press the line 3 button to save the new Stage 1 time. The number will stop flashing. If a time is set for Stage 1, the user will be able to activate the timed preinfusion program by moving the group head handle all the way to the left into the brew position. The brew valve will open and the pump will turn on after the set time for Stage 1 has elapsed.

To cycle to the next display screen in the menu level, press the Next Screen Button.

PROGRAMMING



Line 1 indicates the brew group to be adjusted.

Lines 2 and 3 will be blank on a Cyncra 2016

Line 4 indicates the option to do an automatic back-flush.

The Auto Flush can be activated by pressing the button associated with line 4.

Place the portafilter used for back- flushing into the selected brew group and turn the actuator to the on position. The machine will now back flush 10 seconds on, followed by 10 seconds off for 5 cycles. Once the Auto-Flush is completed, turn off the brew group to allow it to reset, remove the portafilter and thoroughly clean the diffuser screen. The machine is now ready for use.

The Auto Flush can be interrupted mid-cycle [Cancel] by turning the brew group actuator to the off position. Interrupting the program will cancel the Auto Flush process, turning the indicator on the control panel back to [Enable], and resetting the program.

PROGRAMMING

(NOTE: Options for adjustments to brew groups 2, and 3 if applicable, will appear on the following screens of the control panel interface. Adjustments for 'Temperature Control' as well as 'Optional Features' on these brew groups will be the same as the instructions for brew group 1. These screens are omitted from this manual for simplicity.)



Line 1 The Steam Tank Temperature Control screen indicates the current temperature being recorded by the steam tank temperature probe ("LOW" in this example). Once this temperature reaches the set point, the digital display will continuously cycle up and down by small increments as the electronics balance the temperature.

Line 2 is indicating the factory set point of 250.0F (121.1C). The adjustable set range for the steam tank is between 200.0F and 265.0F (93.33C and 129.44C).

Line 3 and 4 are indicating that loops 1 and 2 of the elements are activated.

To change the temperature set point, press the button next to line 2. The current set temperature (250.0F), will begin to flash. To adjust the temperature settings, press the up and down arrow buttons until the desired temperature is reached. Press the button next to line 2 to confirm the new temperature setting.

To turn off loop 1 or 2 of the element, press the button associated with the appropriate line. The indicator reading [Active] will begin to flash. Press either the Up or Down Arrow buttons to select [off], followed by the line 3 or 4 button accordingly, to confirm the selection.

NOTE: Turning off either loop 1 or 2 of the element can be used as a troubleshooting procedure and is not a recommended method of energy conservation.

To cycle to the next display screen in the menu level, press the Next Screen button.

PROGRAMMING



Line 1 indicates that you are on the Hot Water Tap control screen.

Line 2 indicates the adjustable amount of time that the hot water tap will run before shutting off.

Line 3 gives the option of setting the hot water time on line 2 by activating the tap and letting the water flow, then shutting it off. The machine will retain the duration of this pour and dispense water for the same length of time when the hot water switch is activated again.

To change the 'Hot Water Tap' time by tenths of a second, press the button associated with line 2. Use the up and down arrow buttons to select the desired time, followed by the line 2 button once again to confirm the selection. The hot water tap will now dispense hot water for the allotted amount of time.

By selecting the line 3 'Program Time' you may set the desired time by placing the cup size you wish to fill under the hot water tap, press the hot water button on the top of the machine, let it reach the desired level and then press the hot water button again. This will automatically set the amount of water just dispensed as the 'Program Time', and the actual time in seconds will appear on line 2.

To cycle to the next display screen in the menu level, press the Next Screen button.

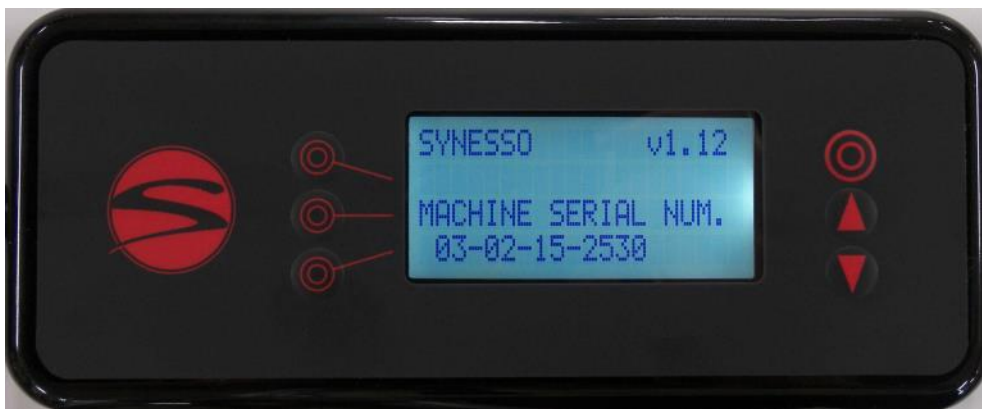

Line 1 of the Serial Number Display indicates the software revision number (Ex: v1.12)

Lines 3 and 4 on the display will indicate the serial number given to this machine.

This screen will show when starting up the machine. Please have this number available if you contact technical support to aid in more rapidly identifying your machine.

PROGRAMMING -Brew System Error Codes



Error Codes are displayed here

In an effort to prevent damage to machines and to help operators troubleshoot issues, Synesso™ has engineered several safeguards into the programming. These codes will help users identify operational issues with the machine as well as automatically prevent greater problems from occurring. By understanding these codes, operators can remedy issues more quickly.

BR - Brew System Codes	GROUP 1	GROUP 2	GROUP 3	CODE DESCRIPTION
BV - Brew valve	BRBV01	BRBV02	BRBV03	Brew Valve has been on for 5 consecutive minutes
OT - Over Temp	BROT01	BROT02	BROT03	Over Temperature (220°F)
UT - Under Temp	BRUT01	BRUT02	BRUT03	Group reads < 180°F for 1 minute while reheating
PR - Pump Relay	BRPR01	BRPR02	BRPR03	Pump Relay coil has been on for 5 consecutive minutes
ST - Steam System Codes				
LOW H2O				Low level probe not in contact with water (audible alarm)
LW - Low Water Probe	STLW00	N/A	N/A	Indicates past LOW H2O warning
FP - Fill Probe	STFP00	N/A	N/A	Fill Probe is not in contact with water for 1 minute
FV - Fill Valve	STFV00	N/A	N/A	Fill Valve has been on for 5 consecutive minutes.
OT - Over Temp	STOT00	N/A	N/A	Over Temperature (270°F)

Example:

After brewing a shot, group 2 was left in the brew position. After 5 minutes, the machine will register a BRBV02 and a BRPR02 error; which translate to “Brew System, Brew Valve Group 2” and “Brew System, Pump Relay is timed out, Group 2.” At this time the machine will automatically shut off both the brew valve and the pump relay to ensure they will not be damaged. They will remain off until the group is returned to the off (far right) position, which allows the group to return to normal operation.

MAINTENANCE

DAILY MAINTENANCE

Proper and regularly scheduled cleaning and maintenance procedures are CRITICAL for trouble-free and optimum quality performance from your espresso machine.

Back Flushing

This process forces water through the inlet tube and drain system. This should be performed on EACH brew group daily. On the current generation of Synesso™ machines, back-flushing can be automated. See page 18.

To back-flush manually:

1. Replace the filter basket with the 'blind' basket, which has no filter holes.
2. Engage the portafilter, turn the head to the BREW position for 10 seconds. Then turn the group off again for 3 seconds. Repeat several times.
3. When using an approved espresso industry detergent during back-flushing, follow the manufacturer's instructions. It is extremely important to thoroughly rinse the blind filter basket and repeat back flushing several times with clean water to clear the system of any detergent residue. Failure to rinse can cause valve problems and bad flavor.

NOTE: NEVER remove the screen and screw when back flushing. Remove and clean them after back flushing is complete. Do not forget to reinstall.

General machine cleaning

1. Clean the surface of the machine using a soft damp cloth. Avoid using abrasive cleaners or cleansing pads. Take extra care on the mirror finish stainless steel surfaces. A "micro-fiber" towel is recommended to avoid scratches.
2. Make sure the steam wands and tips are free of milk build-up. It is always best to clean the steam wand and tip after each use. Approved espresso industry cleaners can be used to dissolve milk build-up. Tips can be removed to soak.
3. The drip tray, drip tray grates, and portafilters should be removed and cleaned every day. If you clean the portafilters in the dishwasher, first remove the filter baskets and springs before washing.

MAINTENANCE

MAINTENANCE SCHEDULE

Daily

1. Back flush each brew group without detergent throughout the day.
2. Back flush with an espresso industry approved detergent during the final cleaning of the night (or after a busy period), and then again without detergent to rinse.
3. Wipe down the entire machine with a soft cloth.
4. Remove portafilters, baskets and springs, drip tray and grates and clean thoroughly. These items are all dishwasher safe.
5. Slowly pour a pitcher of hot water down the drain to clear grounds debris and prevent blockage.

Weekly

1. Soak portafilters and the removed filter baskets in an approved espresso industry detergent and water solution overnight. Rinse thoroughly before reassembling and using your portafilters.
2. Carefully remove screens from each brew group using a short handled screwdriver and soak overnight in a similar solution as the portafilters.
3. Rinse screens thoroughly before installing and using. Make sure you install the screens before brewing any shots of espresso. Failure to do so may plug the drain lines with coffee grounds.

Monthly

1. Check your water filtration system and make sure the cartridges and filters are changed as needed. In areas of high mineral content, hard water, high particulate count or in very busy locations, the filtration systems will need to be checked more often.

Quarterly

1. Change portafilter gaskets and closely inspect diffuser screens and filter baskets, If these items are showing wear, please replace them as soon as possible. Change these items if they show damage or overuse.
2. Briefly inspect the machine for leaks or potential issues. Contact Synesso™ or your local distributor or service agent to order parts and/or request service.

Synesso™ recommends that you contact your distributor or service agent for periodic maintenance. The frequency of maintenance visits will depend on a variety of factors including how much use the machine receives, but at least one preventative maintenance visit a year is required. During this yearly service, all body panels must be removed and all connections both electrical and hydraulic must be inspected. Small problems can become large if not caught early.

TROUBLESHOOTING

This is a troubleshooting guide for some of the common issues that operators might encounter. For more detailed assistance with technical issues, contact your distributor or local service agent.

The machine may be reset by powering off for 10 seconds.

Brewing problems

The shot is pouring too slowly:

- Tamp pressure was too firm
- Too much coffee is in the basket
- The grind is too fine
- Diffusion screens are clogged; clean or replace
- Pump pressure is too low. Ensure that it is set between 8-9.5 bar
- Brew jet is clogged; when operating properly, 60ml should flow out within 8 seconds

The shot is pouring too quickly:

- Tamp pressure is too light
- Not enough coffee in the basket
- Grind is too coarse
- Portafilter baskets are worn or cracked; replace
- Brew temperature is too cold

Crema is thin with large bubbles and tastes astringent:

- Coffee is old
- Grinder burrs are dull
- Brew temperature may be set too low

Diffuser screen is loose:

- This is most likely caused by over filling the portafilter basket with coffee. This causes the expanding coffee puck to push against the diffuser and bend the screen-to-screw contact point away from the screw.

No pump pressure when water flows from the group:

- Check position of group head: ensure that it is in the brew position.
- Pump relay may have failed
- Stage 1 time may be set to run too long.

The pump comes on, gauge reads full pressure, but no water comes out:

- Diffuser screen/screw, or jet is clogged (can be caused by soap residue not fully flushed after cleaning).
- The water filter is clogged and needs changing
- Brew solenoid has been sealed shut by dried soap or has failed.

Low Water Probe is Beeping - It is either covered with scale and unable to sense water or is exposed

- Water to the machine has been turned OFF and needs to be turned back ON

TROUBLESHOOTING

- Fill valve has a 5 minute “timed out” feature - Power off machine to reset
- Your water filtration system is plugged or restricting the water flow
- RO System is not adequate

Brew Gauge

Brew Pressure gauge needle value changes often:

- This is normal. The lowest number (usually 3-5 bar) reflects the incoming line pressure. When brewing the needle reflects brew pressure (8.5-9 bar). When the brew tanks heat, the water expands and the expansion valve relieves the pressure at 11 or 12 Bar.

Brew Pressure is Low:

- Check pump to make sure pressure is properly set
- Water supply hose to the pump is kinked
- Water filter is plugged. Check and replace if necessary

Pump Motor Runs; No Brew Pressure:

- Failed pump, needs to be replaced
- Brew Solenoid is stuck (can be caused by soap residue not fully flushed after cleaning).
- Brew Solenoid has failed
- The line between the pump and the water supply has collapsed or is kinked
- Hose to the pump is kinked
- Water filter is plugged. Check and replace if necessary
- Water supply is inadequate

Readout for Brew Water Temperature Varies by a Few Degrees:

- The control must “see” the increment just above the set point before it sends a signal to turn off the heating element. This will allow the electronics to show a reading just above the set point. The energy from the heating element and the tube for the preheated incoming water are within 1” or 25mm from the location of the temperature sensing probe in the coffee tank. The water pick up tube for brew water is at the top of the brew group and is in the most temperature stable water in the tank. Meaning, the readout can show a temperature of a few degrees above your set point, and may fluctuate due to the heat from the element or heat exchanger, but your brew water is actually at the set point.

Electronics

All zones read LOW:

- Check to make sure the element breaker is ON (**Element Rocker Switch is to the LEFT**). Zones will read low until the temperature in that zone reaches 175° F. Please allow 20-30 minutes to heat up initially.

TROUBLESHOOTING

Steam Wand

Drip at the Steam Wand Tip:

- Steam valve seal is worn. Replace by installing steam valve rebuilt kit.
- Steam valve is filled with milk residue. Disassemble steam valve and clean.

Wand is Hard to Move or Sticky:

- Remove wand at the nut, clean and lubricate moving parts with food grade grease

Steam

Sudden loss of steam pressure:

- Commonly caused from drawing large amounts of hot water while steaming milk. Allow the machine time to recover pressure. Check temperature settings on Steam 1 and 2 to make sure they are high enough for your application. Watch the steam gauge when the pressure drops; allow the heating elements to heat the incoming cold water. When it reads above 1.1 bar, hot water and steam may be dispensed again.
- Check the programming keypad to make sure all temperatures, especially in the steam tank, are close to their set points.
- Check the element breaker on the electronics box to make sure the heating elements are ON (element switch is to the left).

Steam Tank is overfilling:

- Water is too soft; this occasionally happens with reverse osmosis water filtration systems. The water level (auto fill) probe needs a minimum mineral content in order to detect water.
- Debris caught in the water control valve or worn out valve.
- Calcium deposits on the fill probe are preventing the probe from detecting the water level.

Steam Valve Stem Seals Leak:

- Replace O-rings. Purchase Rebuild Kit

The Sight Glass shows over or under filled steam tank:

- Machine is not level. Check to make sure the surface that holds the machine is level. Slightly adjust leg height to level the machine.
- Water level is too high; use the hot water spout to drain water from the steam tank. Continue releasing hot water until the autofill system activates. Once autofill stops, recheck the water level.
- Debris is stuck in the water control fill valve.

Annual Warranty Checklist

To qualify for the Synesso 2 and 5 year warranty, this checklist must be returned the Synesso within 30 days of 1 year in service.

- Replace portafilter gaskets**
 - 8.4mm 1.3440 (standard size)
 - 9.0mm 1.3430 (for older handles with worn ears)
- Replace group diffuser screens**
 - Synesso reinforced screen 1.3292
- Inspect portafilter baskets for wear or damage. Replace if necessary**
 - 14 gram basket 1.7000
 - 18 gram basket 1.7090
 - 21 gram basket 1.7170
- Rebuild or replace steam valves. Clean and lubricate wand pivot ball and pusher face**
 - Rebuild kit 1.7320
 - Complete valve 1.4501
 - Remove and clean steam tips
- Remove side and splash panels, inspect tanks, copper tubes, and all fittings for leaks**
- Inspect and replace all ruby flow restrictors and brew valves**
 - Ruby jet replacement kit 1.3191
 - Brew valve 1.2460
- Inspect brew valve drain manifold. Replace worn or cracked drain hose**
 - Drain manifold black hose= 1.3261
- Check flow rate at each brew group. 2oz water in 6-8 seconds**
- Check that expansion valve does not leak at 9bar. 11-12 bar is the factory standard setting**
 - Expansion valve 1.4070
- Check line, bypass, and pump pressures**
- Replace steam tank vacuum breaker**
 - Vacuum breaker 1.4265
- Inspect steam tank pressure relief valve (dark spots may indicate leaking). Replace if signs of leaking.**
 - Pressure relief valve 1.4100
- Depressurize steam and brew systems, check that gauges return to zero. Replace if not accurate.**
 - 0-60psi steam gauge 1.4083
 - 0-300psi brew gauge 1.3373
- Remove and inspect level probes. Clean scale build up if necessary**
 - Upper level probe (fill probe) 1.4111
 - Lower (safety) probe 1.4112
- Inspect sight glass and drain valve for leaks. Rebuild if signs of leaking**
 - Sight glass rebuild (6 o-rings) 4x 1.5300 + 2x 1.5290
 - 1st Gen sight glass needs additional 1.5280 o-ring
- Inspect drain hose for clogs or leaks**
- Check element gaskets for signs of leaking, tighten if needed**
- Test handheld controller for proper operation. All buttons react as normal**
- Test steam tank element set points. Cycle each loop of element**